



# INTERIOR BADGE LIGHT

SERVICE # VRJ7Z-13776-A CORSAIR

SERVICE # VRB5Z-13776-A ESCAPE / EXPLORER / BRONCO SPORT

SERVICE # VRK9Z-13776-A MACH-E

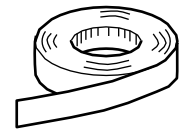
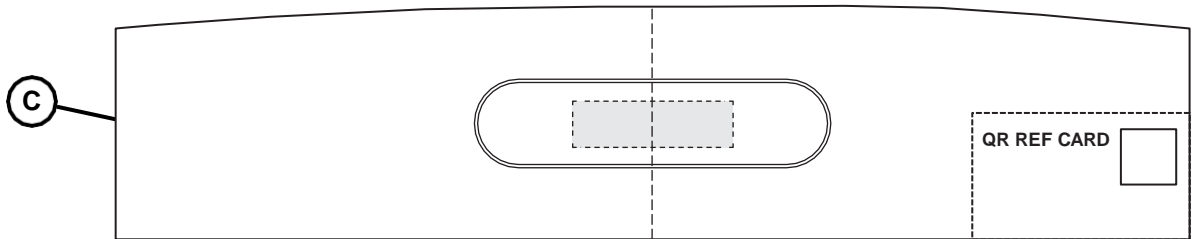
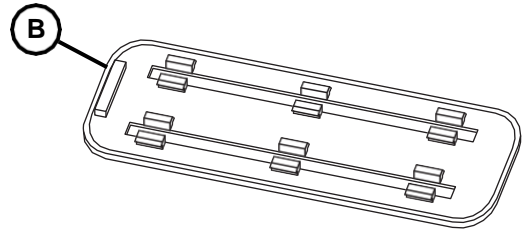
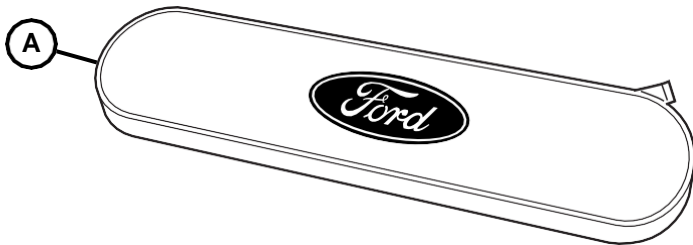

1

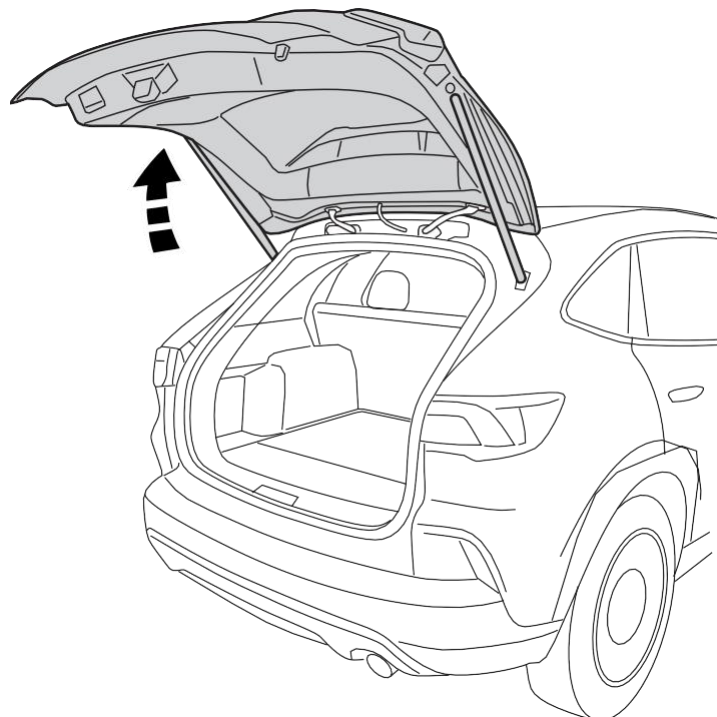

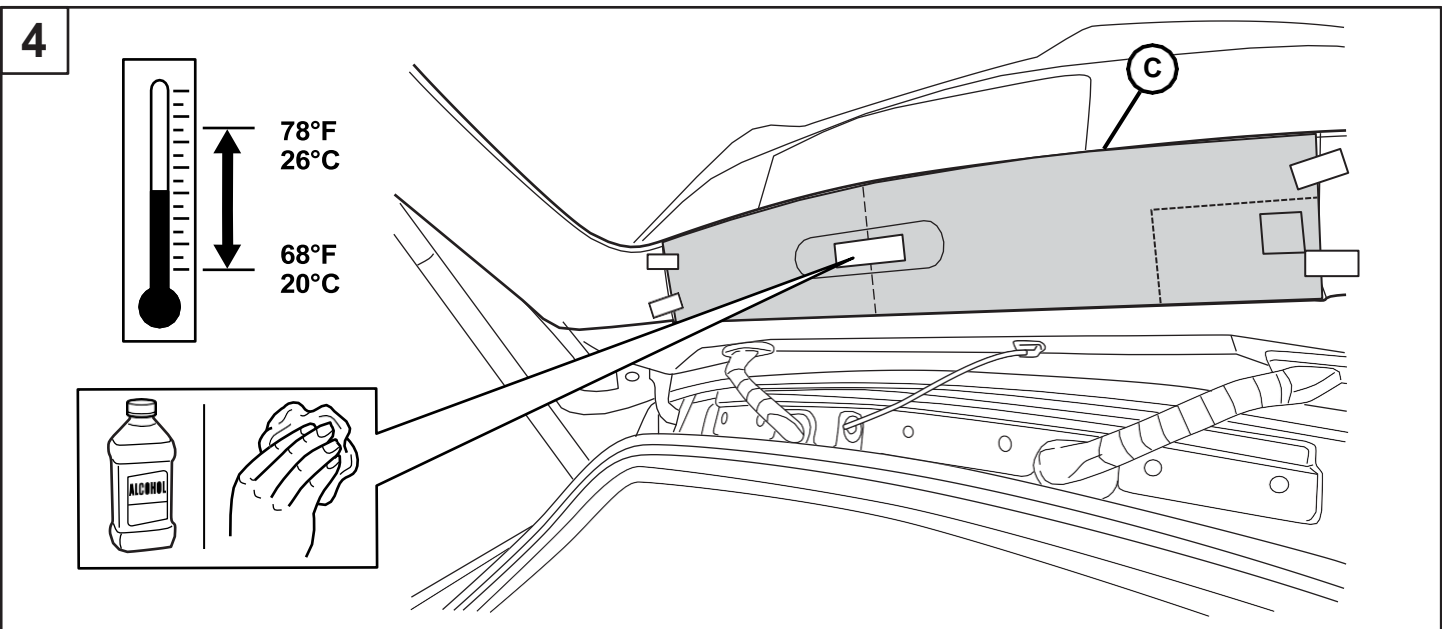
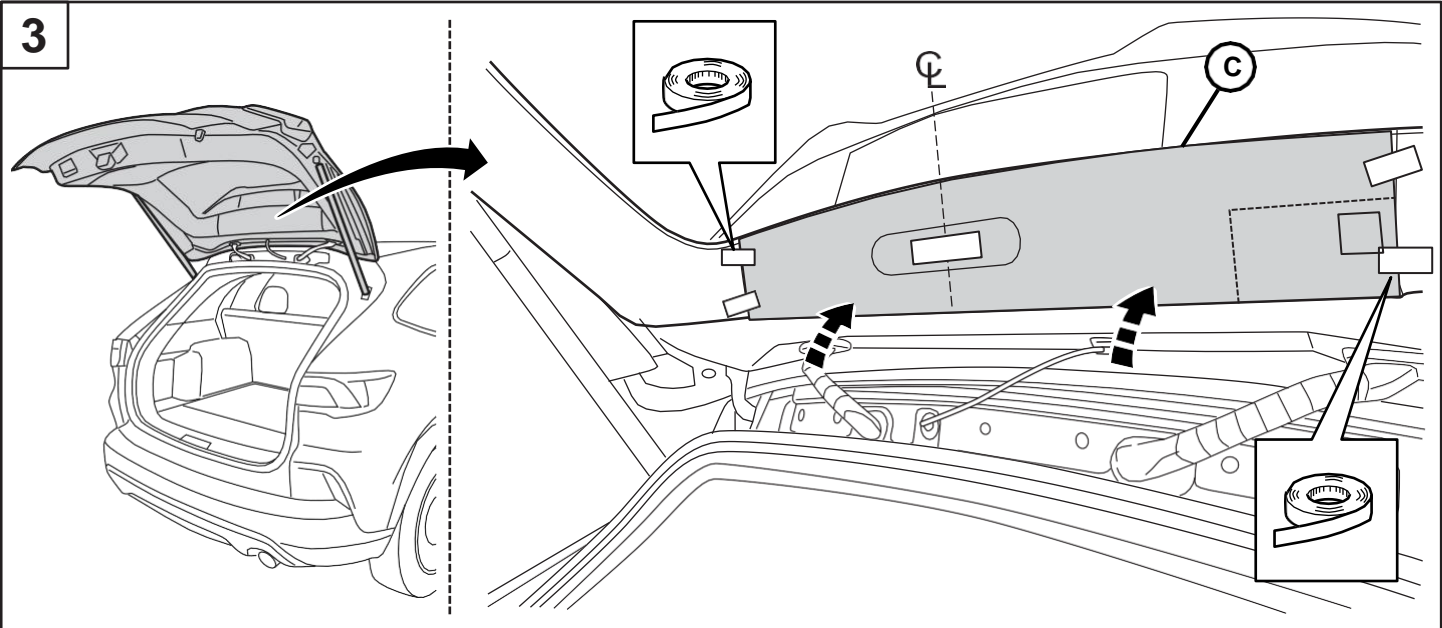
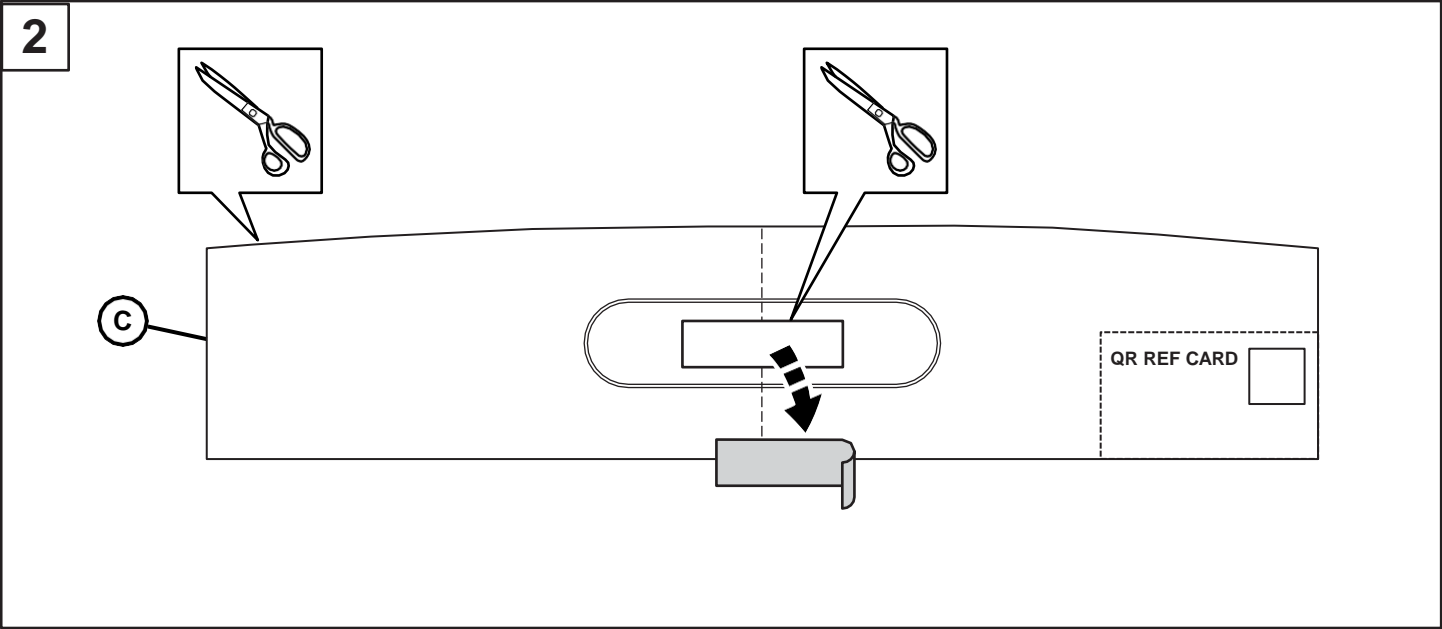

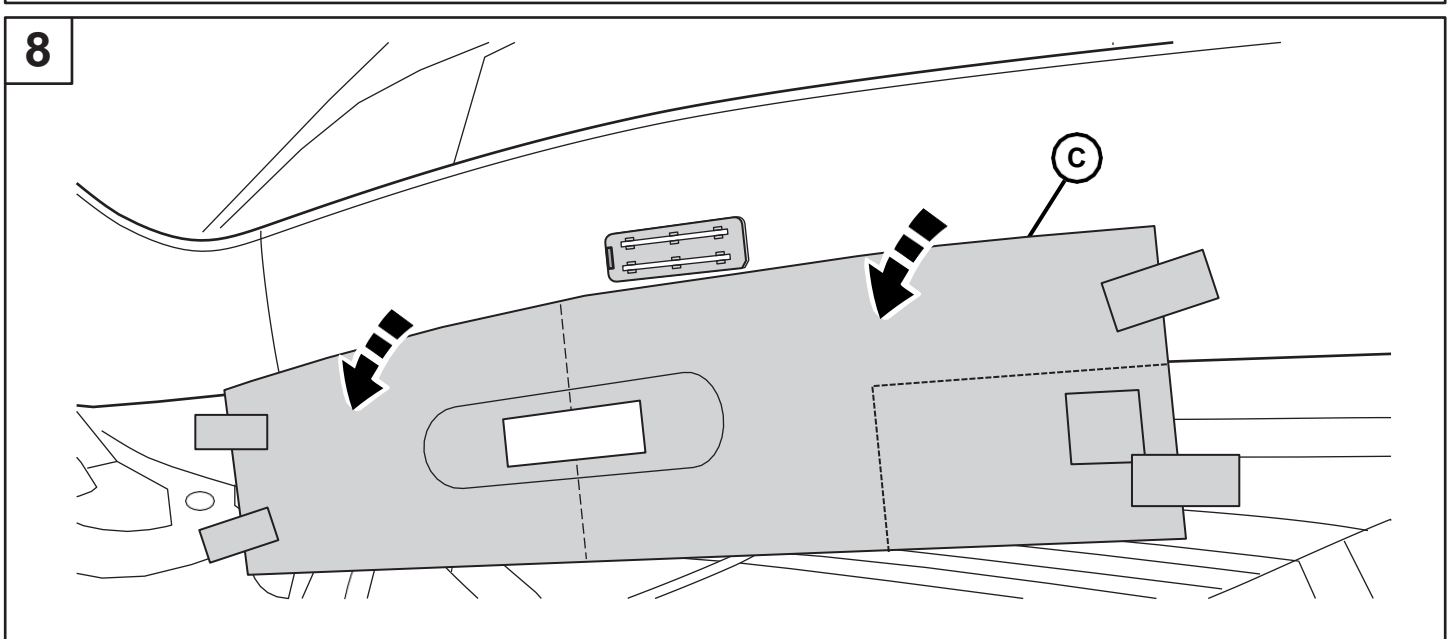
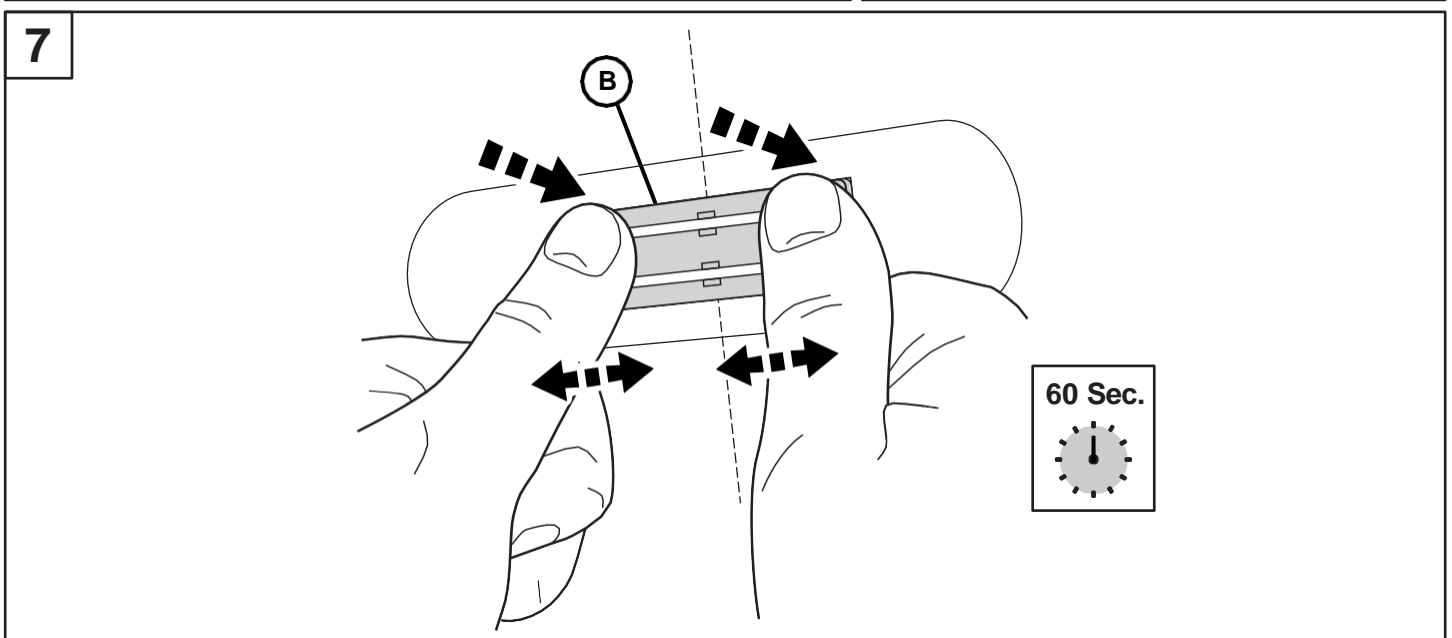
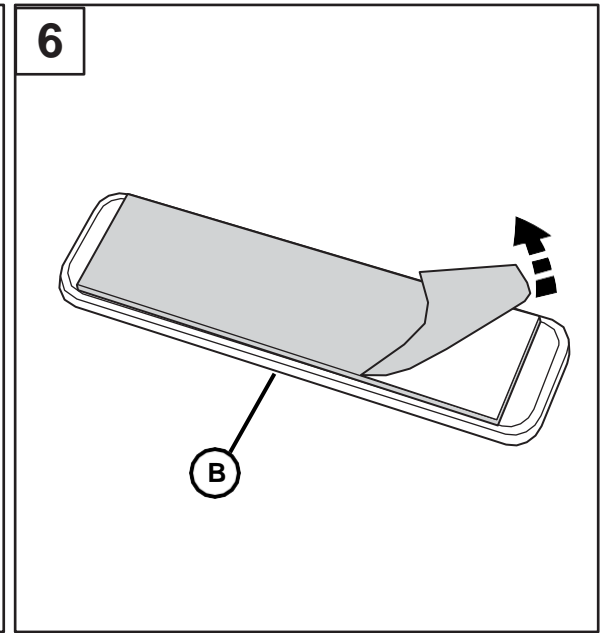
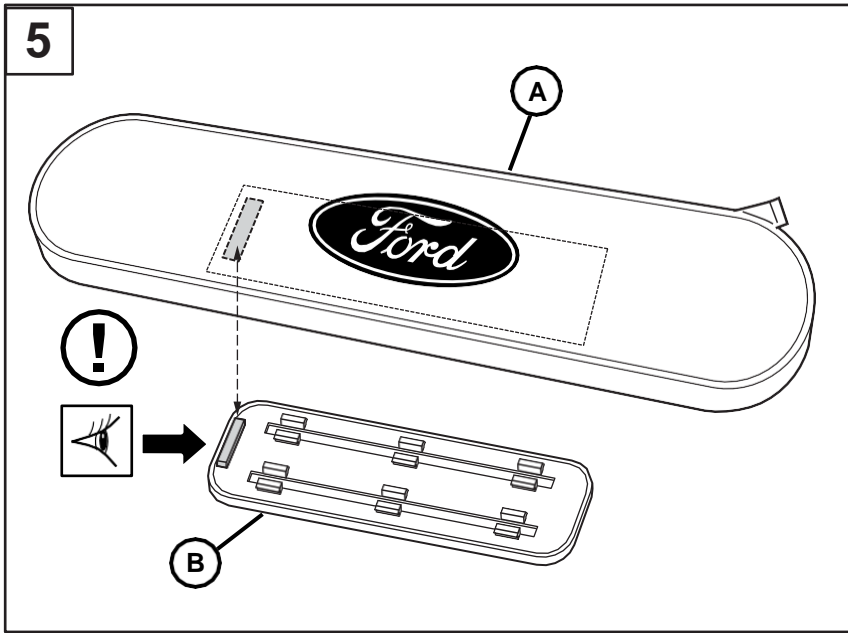

9

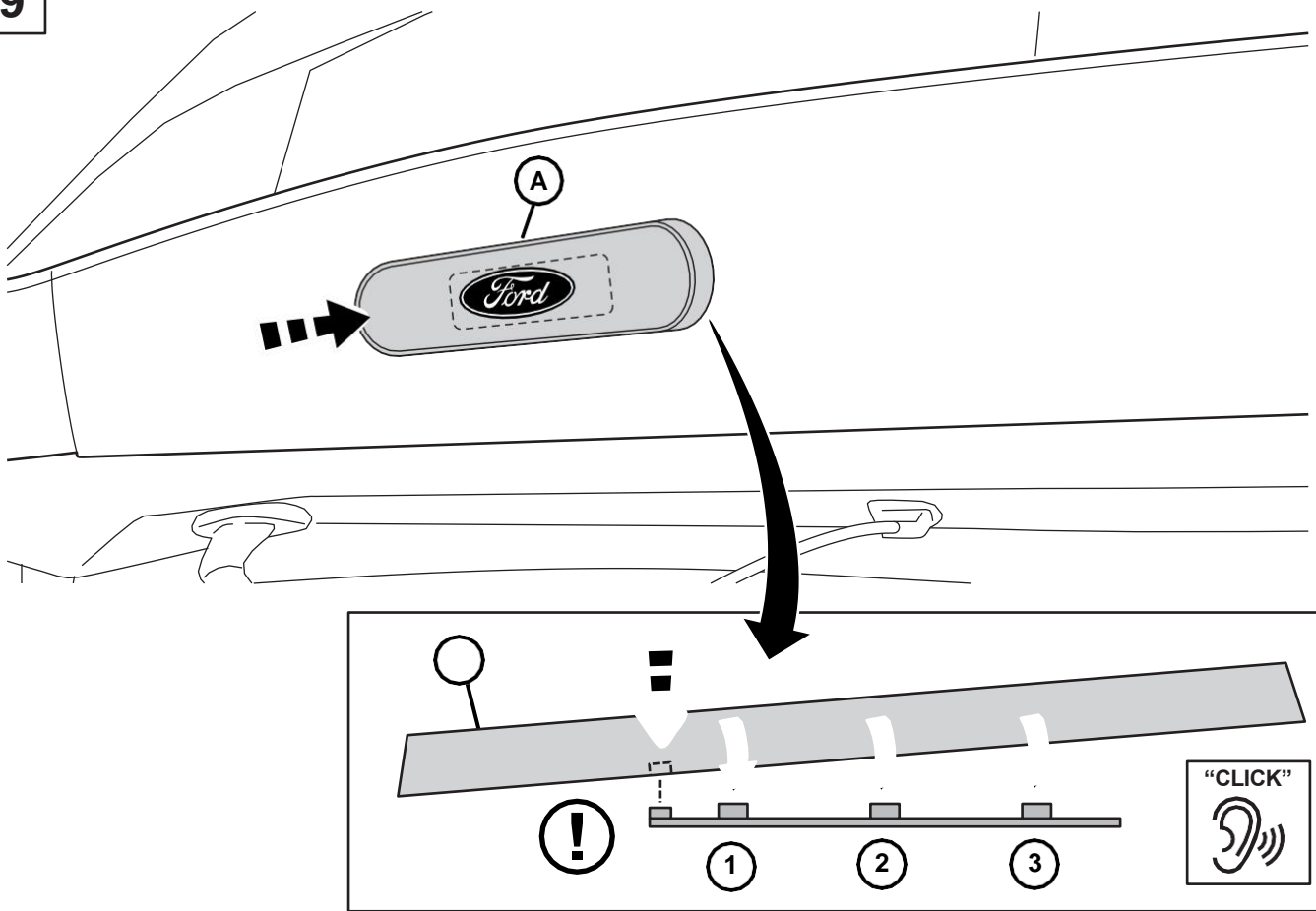

10

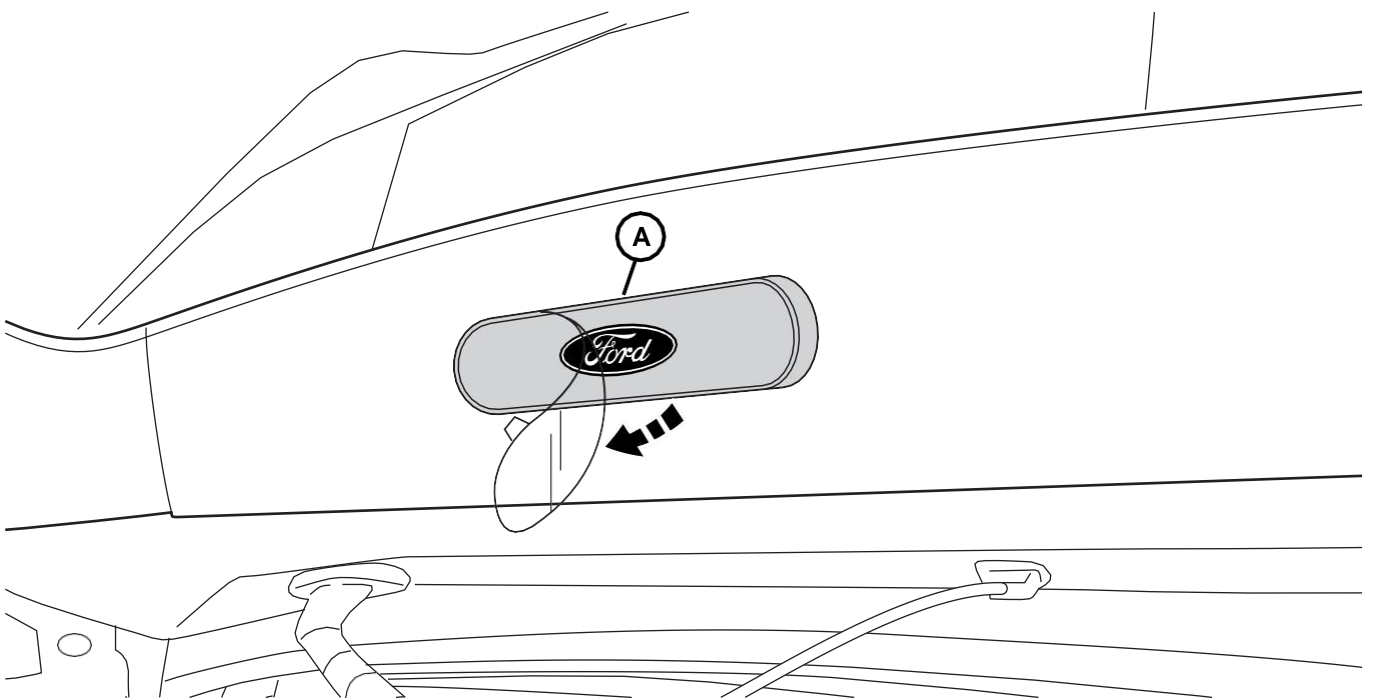

11

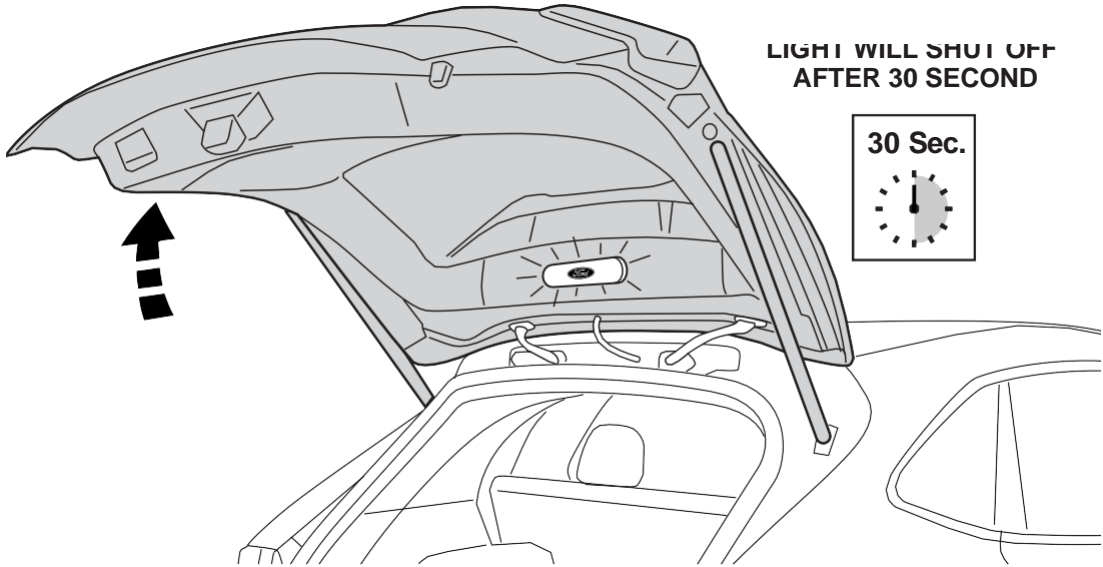

12

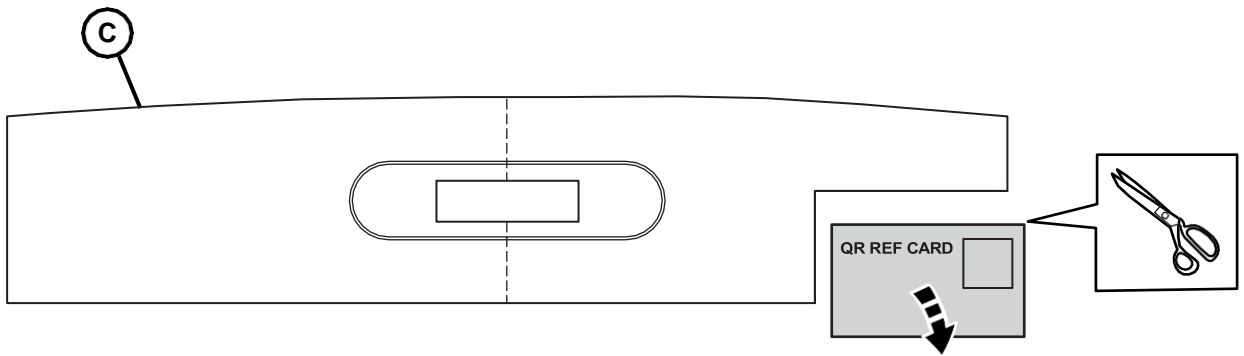

13

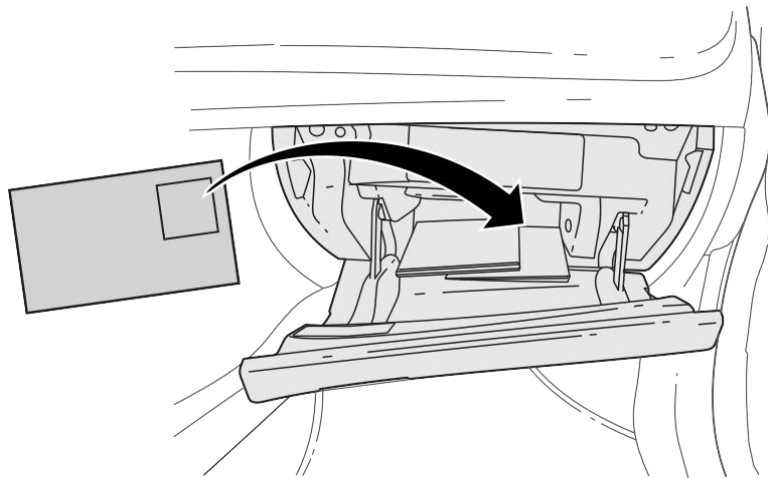

# BATTERY REPLACEMENT

1

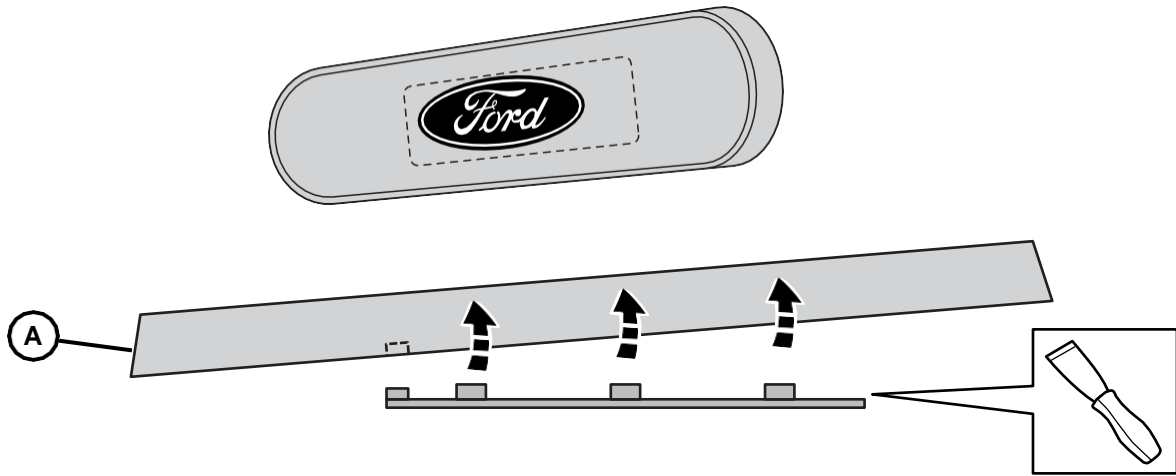

2

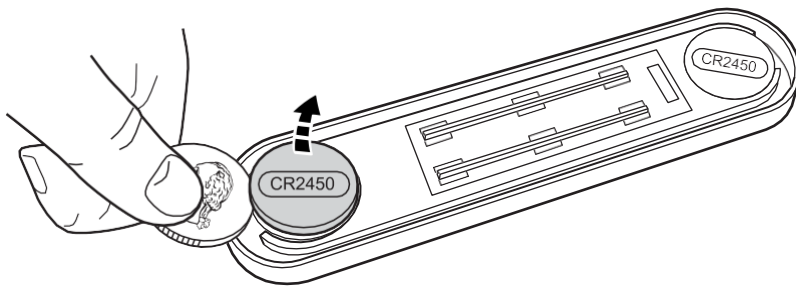

3

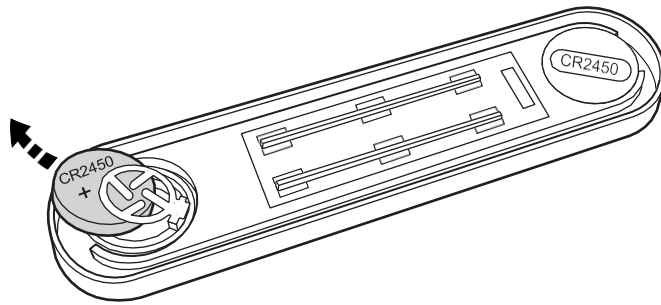

4

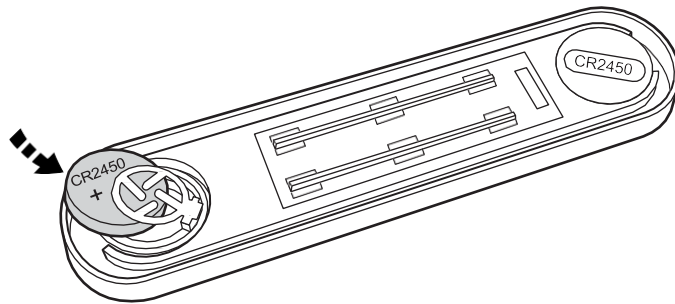

5

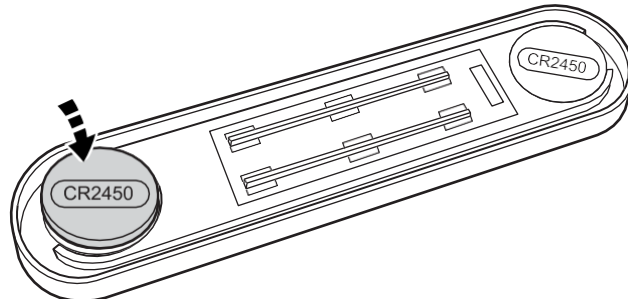



# BGM Engineering Inc.

## LIMITED WARRANTY

All Ford part numbers provided by BGM Engineering Inc. are warranted to be free from defects in materials or workmanship on products properly installed per the installation instructions provided with the product. This warranty covers repair or replacement of any defective product at no charge during the applicable warranty period listed below. Labor for replacement or service of defective product is not paid or reimbursed by BGM Engineering Inc.

WARRANTY PERIOD		
	USA	Outside USA
Product which appears on New Vehicle Monroney Label (window sticker)	Coverage which matches new vehicle warranty--- Ford - 3 years or 36,000 miles whichever comes first; Lincoln 4 years or 50,000 miles whichever comes first	Coverage which matches new vehicle warranty --- Ford - 3 years or 60,000 kilometers whichever comes first; Lincoln 4 years or 80,000 km whichever comes first
Part purchased and installed during or after the original vehicle warranty	Whichever of the following options which provides the greater benefit to the customer: 1) 2 years / unlimited miles or 2) The remainder of the new vehicle warranty	Whichever of the following options which provides the greater benefit to the customer: 1) 2 years / unlimited kilometers or 2) The remainder of the new vehicle warranty

This limited warranty does not cover any damage, defect or malfunction caused by misuse, abuse, accident, improper installation, modification or improper or lack of maintenance. Incidental and consequential damages are not recoverable under this warranty. This warranty offers you specific legal rights. You may have additional or other rights as which vary from state to state or province to province.

If you experience a warranty issue with this product please visit your Ford dealer. If the repair is covered by the warranty above and completed by the dealership, labor is also covered by Ford -- Ford Warranty and Policy – Section 3.

Please note that BGM Engineering Inc. has replacement component parts available to assist consumers and dealers to resolve warranty and non-warranty issues as quickly as possible.

### Note to dealer:

Ford dealers should contact Dan Labruyere, Inc. by phone at (586) 685-1534 and ask to speak to the warranty administrator or by email to Dan at [dlabruyere@bgmeng.com](mailto:dlabruyere@bgmeng.com)